

智元 D1 Pro

产品说明书



1.版本申明

- 01 法律声明
- 02 注意事项
- 03 电池和充电注意事项

2.产品说明

- 01 产品概述
- 02 部件介绍
- 03 尾灯介绍
- 04 电源介绍

3.产品使用

- 01 首次使用前准备
- 02 遥控器使用说明
- 03 APP使用说明
- 04 产品 OTA升级

4.产品参数

5.故障排除

- 01 产品运输
- 02 存储运输
- 03 电池注意事项
- 04 轻拿轻放

6.有害物质说明

7.保修说明

- 01 售后服务
- 02 保修政策
- 03 保修范围
- 04 送修说明

法律声明

在使用本产品前，请用户务必仔细阅读本产品使用说明书，并严格按照本手册内容操作本产品。任何违反本手册内容使用而造成的财产损失或人身伤害，本公司概不负责。本产品由多个零部件构成，请确保儿童无法接触本产品，以避免意外发生。本产品仅限 18 周岁以上人士使用。为延长产品使用寿命，请勿在高温、高压环境中使用。本手册尽可能包含本产品的功能介绍和使用说明，但由于功能不断完善和设计变更等原因，实物与手册内容可能存在偏差。如实物与本手册在颜色、外观等方面有出入，请以实物为准。

注意事项

本说明书适用于D1 Pro版本（产品型号：ZYCXD105P）。

- 本产品不可由身体、感官或智力残障人士以及无相关经验与知识之人士（包括儿童）使用，除非有监护人的看管或指导，以确保其能够安全使用本产品。
- 请勿让儿童将机器人当成玩具，主机工作时请监督儿童及宠物使其尽量远离。
- 如果电源软线损坏，必须用专用软线或从其制造商或维修部购买到的专用组件来更换。
- 请勿在悬空环境没有防护栏的情况下使用。
- 当机器狗在使用过程中出现腿乱摆、剧烈晃动等非正常现象时，请按下【紧急停止】键以启动软急停功能，使正在运动的机器狗进入保护状态。机器狗将自动趴下，待排查问题后，即可正常操作机器狗。
- 请勿将机器狗倒扣放置。请勿将狗腿作为提手搬运。
- 请勿在高于40°C、低于0°C的环境下使用。
- 请勿在电磁干扰环境下运行机器人。
- 请勿在WIFI或2.4G信号干扰环境下运行机器人。
- 机器狗启动之前，请确保周围有1米以上的空间，避免与人或物体发生碰撞。
- 机器狗通过楼梯或斜坡时，请勿站在机器狗下方的楼梯、平台或斜坡上，以避免机器狗跌落时可能会造成的人员损伤。
- 请勿将儿童或宠物以及任何物品放置在静止或运行中的主机上。
- 搬运时请勿把手伸入关节运动范围内，以防止夹伤甚至划伤。
- 清洁和维护主机及充电座前请关机并将电源插头拔出。
- 请勿使用湿布擦拭或任何液体冲洗主机、充电座。
- 请勿使用任何第三方电池、电源线或充电座，仅可与标配充电座配套使用。
- 请勿私自拆解、修理、改装主机、电池或充电座，拆解、修理和改装之后将不再提供质保服务。
- 请勿将充电座靠近热源放置。
- 请勿随意抛弃废弃电池，应交由专业回收机构处理。
- 如长时间不使用本产品，请充满电后关闭主机并放置于阴凉干燥处，至少每3个月充电一次避免电池出现过放。
- 如需运输产品，请确保主机处于关机状态，并建议使用原包装盒包装。
- 请依照说明书的指示使用本产品，因不当使用导致的任何损失和伤害，由用户自行承担。

注意事项

关节和线束检查

- 请检查各关节是否有异物影响，线束是否有破损，并确保足垫完好无损。

电池电量与相机清洁

- 检查电池电量，确保充足，避免突然倒地或摔倒。同时，请保持头部和机身腹部相机表面清洁，避免用硬物划伤镜片，如有污垢，请及时用干软布擦拭。

清洁产品注意事项

- 请勿使用含酒精等有溶解或腐蚀成分的液体清洁本产品。

合理放置与地面环境

- 放置时，请确保腿部自然无负重状态，避免机身重力对腿部关节造成伤害。避免使产品趴在坚硬、尖锐或凸起过多的地面上，以免划伤机身底部镜片。

足垫和磨损

- 足垫是消耗品，使用时应留意磨损情况。发现磨损、破损或机器人对地面冲击噪音增大时，请及时更换足垫，以免损害机器人的运动。

安全使用和地形适应性

- 使用时请保持在视线范围内，并预留足够安全距离，远离障碍物和可能碰撞的障碍物。尽管产品具有良好的地形适应性，但仍需注意地形是否符合要求。

速度、转弯和复杂地形

- 快速转弯容易失控，尤其在陡坡、不平坦或未知地形，避免冒险操作，降低速度。

注意事项

陡坡和爬坡角度

- 限制在额定正向爬坡角度以内，并避免在较大爬坡角度下直接转弯，以免机器人失稳。请妥善控制在陡坡和坡度大的地形的操作。

最高速度和禁止使用场合

- 在平整地形下最高开放速度可达 3.5m/s。禁止在复杂地面、湿滑地面、有杂物的地面、超过规格的坡度地面或附近有尖锐物体的场合使用本产品。

关节和电池状态检查

- 如果发现关节松动、无法正常站立、运行噪音过大，请立即停止使用并检查关机，寻求专业维修。

低电量警示

- 在电量显示低的状态下，产品可能没有足够动力执行动作，请及时充电以避免危险。

安全注意事项

- 避免手部或身体接触机器人运动部件，以免夹伤或碰伤。同时，避免接触关节电机表面的金属部件，以免烫伤。

产品散热和清理

- 长时间连续使用可能导致电机过热，请定期休息。如产品受污染，请及时清理。

电源连接规格

- 请使用符合规格的快充线连接本产品。

关机注意

- 使用完毕后，请立即关机。

电池和充电注意事项

电池使用限制

- 禁止拆卸电池或将电池极片通过任何方式引出使用。

适配器和清洁

- 禁止使用酒精或其他可燃剂清洁电源适配器，避免潜在的安全风险。

应对电池泄漏

若电池发生泄漏导致电解液进入眼睛，请避免揉擦，并立即用清水冲洗眼睛，随后寻求医疗治疗。

异常情况处理

- 如充电过程中电池出现异味、冒烟、变形或其他异常情况，请立即拔掉电源适配器并进行检查。

安全温度

- 充电时的电源适配器可能会产生较高温度，请避免长时间触摸，以防止烫伤。

电源适配器

- 请勿使用已损坏的电源适配器，仅限使用官方电源适配器。非官方电源适配器可能导致锂电池泄漏、发热、起火或爆炸。

充电时间

- 电池充电时间不应超过 24小时，过度充电可能缩短电池寿命。

产品概述

D1是一款通用型智能仿生四足机器人，拥有 12 个自由度，具有多种运动步态和运动动作。同时Edu版本开放了运动控制算法开发 SDK和通信协议，允许用户根据需要进行二次开发。



部件介绍

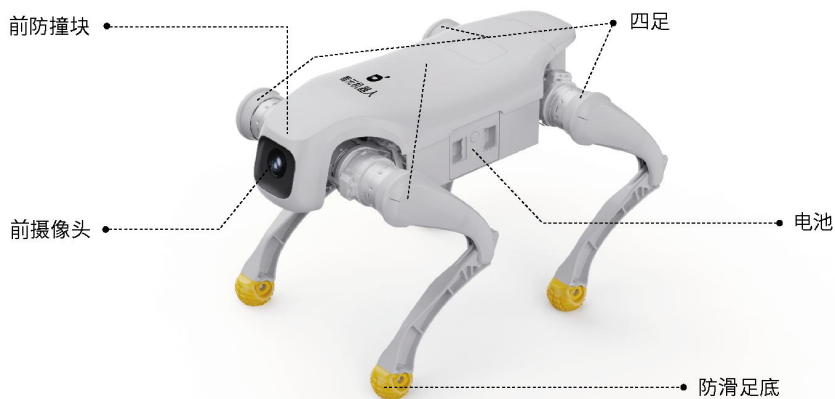

拓展接口（可选配置，Edu版本适用）

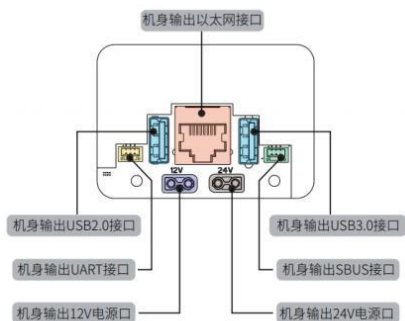

序号	接口名称	数量	说明
1	以太网口	1	RJ45 接口，支持 1000Mbps 传输速率，用于高速数据传输，支持网络连接、远程监控、数据传输等应用。
2	USB 接口	2	Type-A 接口，支持 USB 3.1 Gen1 (5Gbps) 速率，用于连接外部存储设备、摄像头、传感器等 USB 设备，提供高速数据传输和电力供应。
3	电源接口	2	标准 DC 电源接口，带锁扣设计，提供稳定的电源供应，支持 12V 和 24VDC 电压输入，满足机器及上位机的电力需求。
4	SBUS接口	1	标准SBUS接口，用于连接遥控器接收器或其他支持SBUS协议的通信设备，实现精确的遥控指令传输。
5	UART接口	1	标准 UART 接口，用于连接嵌入式系统、通信设备或其他支持 UART 协议的设备，通过异步串行通信实现设备间的数据交换与控制。

尾灯介绍

序号	接口名称	说明
蓝色常亮	开机完成	
蓝色闪烁	开机中	
白色常亮	实验室模式	此模式下运动能力提升并解锁特技
绿灯常亮	追踪模式开启	
黄灯常亮	电池电量低于 20%	电池电量不足，无法开启实验室模式
黄灯闪烁	电池电量低于 5%	电池电量不足，需立即充电
红灯常亮	关节温度过高，需要冷却	
红灯闪烁	系统异常，需要联系售后	

电源介绍

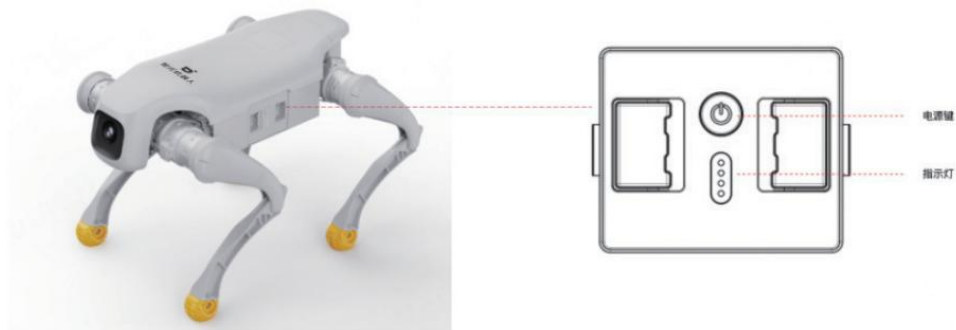

开机状态下电池显示

Battery capacity LED indication (idle&discharge)					
NO.	SOC(%)	LED1	LED2	LED3	LED4
1	0~14	Flashing	OFF	OFF	OFF
2	15~24	ON	OFF	OFF	OFF
3	25~49	ON	ON	OFF	OFF
4	50~74	ON	ON	ON	OFF
5	75~100	ON	ON	ON	ON

充电状态下电池显示

Battery capacity LED indication (charging)					
NO.	SOC(%)	LED1	LED2	LED3	LED4
1	0~24	Flashing	OFF	OFF	OFF
2	25~49	ON	Flashing	OFF	OFF
3	50~74	ON	ON	Flashing	OFF
4	75~99	ON	ON	ON	Flashing
5	100	ON	ON	ON	ON

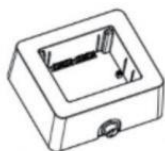

充电座×1



适配器×1



适配器电源线×1

不亮灯	未通电
亮灯	接通电源 (100v~240v)

首次使用前准备

①开箱

机器狗应在关机状态下整体抬出航空箱；操作时须双手托举机身，避免腿部承重；腿部仅允许沿关节自由度方向进行小角度辅助调整；严禁逆关节限位方向用力掰动；不规范操作可能导致关节限位损伤、编码器偏移或站立异常！

②开机

将机器狗从包装箱中取出,放在平整的地面上。将电池取出,插入到机器狗的电池仓中。按电源键一下后再长按3秒以上，机器狗头顶的LED灯闪烁完成后即开机成功。

③关机

机器狗需要确保处于趴下姿态，然后按电源键一下，接着长按电源3秒以上，电池上的所有 LED 灯都灭完以后，进入关机状态。



遥控器使用说明

产品使用声明：由于产品软件版本不断升级，部分功能、操作方式或界面显示可能与本说明书描述有所不同。如有任何疑问或操作困惑，请随时联系官方客服获取技术支持。

遥控器介绍

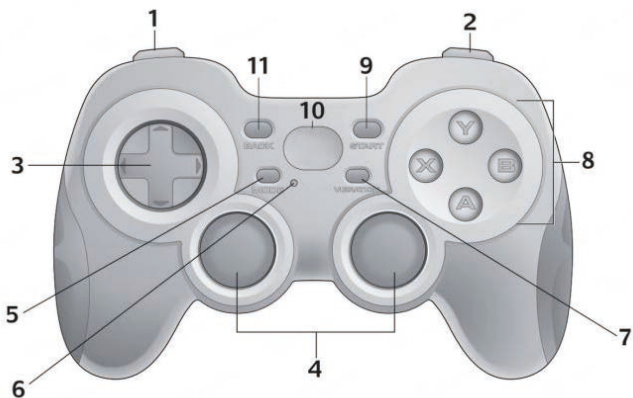

操控说明

键位	D1 Pro遥控按键名称及意义
1. 左键 / 触发器	LB、LT 按键
2. 右键 / 触发器	RB、RT 按键
3. 方向键	左侧十字按键
4. 摇杆	LS: 左摇杆 (可控前后左右方向) RS: 右摇杆 (可控制转向方向)
5. 模式按钮	/
6. 模式 / 状态灯	状态指示灯
7. 振动按钮	/
8. 四个动作按钮	A、B、X 和 Y 功能按键
9.“START” 按钮	START 按键
10. 按键	/
11. 返回按钮	/

连接方式

1. 将电池取出,插入到机器狗的电池仓中。短按电池电源键一次,再长按5秒,松开后等待20秒,即完成开机。此时,电池指示灯显示当前机器狗的剩余电量。

2. 查看遥控器上方, 确定在X档位。

3. LB+Y让机器狗站立, 轻前推左摇杆尝试控制机器狗前进, 若机器狗无反应, 按MODE键后, 再轻前推左摇杆。

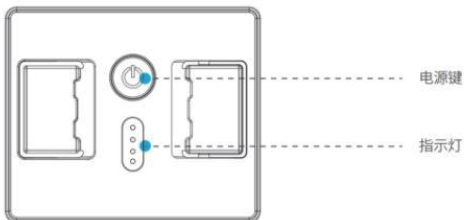

动作操控说明

分类	动作	按键
常规 / 实验室模式切换	-	START+BACK
通用动作	站立	LB+Y
	阻尼 (缓慢趴下)	LB+X
	卧倒 (紧急停止)	LB+RB
移动动作	前后左右移动	左侧摇杆前 / 后 / 左 / 右推
原地动作	原地 / 移动切换	START+B
	俯仰调整	右侧摇杆前 / 后推
	水平转身	右侧摇杆左 / 右推
	左 / 右探头	X/B
	高 / 低身形	Y/A
特技动作	向上跳	RB+A
	向前跳	RB+X
	后空翻	RB+B
	打招呼	RB+Y
	双腿站立	LB+A

△ 警告：特技动作可能影响设备寿命

在实验室模式下执行特技动作会对设备的关节模组施加较大负荷，长时间运行可能导致关节加速磨损，严重影响其使用寿命。请谨慎开启，并合理控制使用时长，以确保设备长期稳定。

APP使用说明

一、APP下载

点击链接<http://www.zhiyuan-robot.com/DOCS/SW/D1/app>，下载 AgibotGO APP。

二、账号注册登录

使用手机号或者邮箱注册并登录 APP。

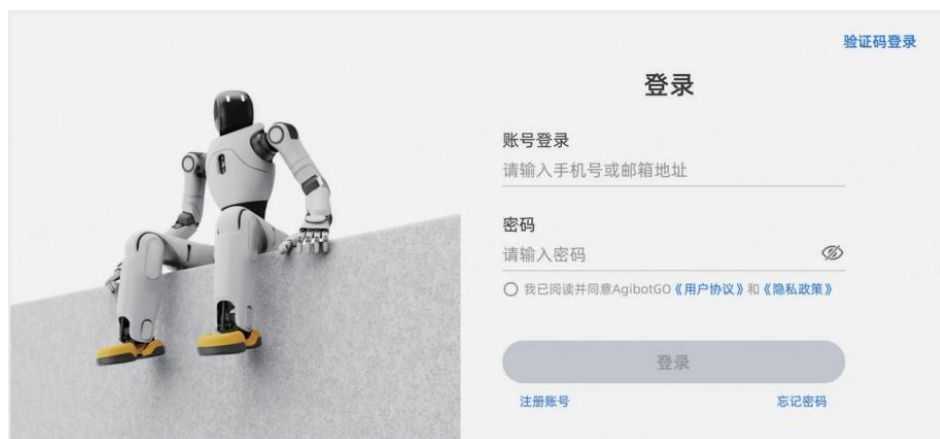

三、设备连接

1. 点击添加机器人按钮



2. 选择添加机器人



3.选择连网模式。支持WiFi和AP直连模式两种。



4. 选择 WiFi 连接模式

自动读取当前手机所连接WiFi 网络



连接中



连接成功，回到APP首页



5. 选择AP连接模式



6. 连接成功后回到设备首页



操作页面

1. 左上角可以切换移动模式和原地模式；

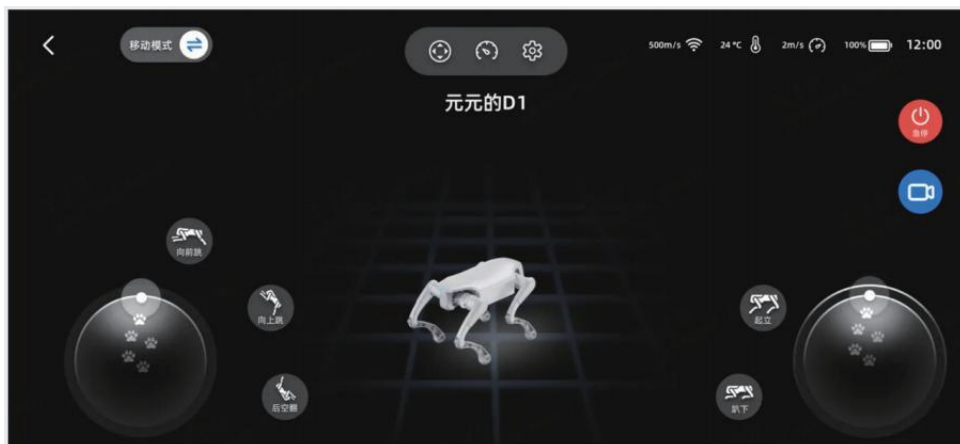

2. 移动模式下，左边摇杆为控制机器人行走方向，右边摇杆为机器人旋转方向。

3. 原地模式下摇杆对应操作切换为左右探头、俯仰。原地模式下机器人无法行走。



4. 击红色急停按钮，触发急停操作。



5. 点击左边向前跳、向上跳、后空翻，提示为特技动作

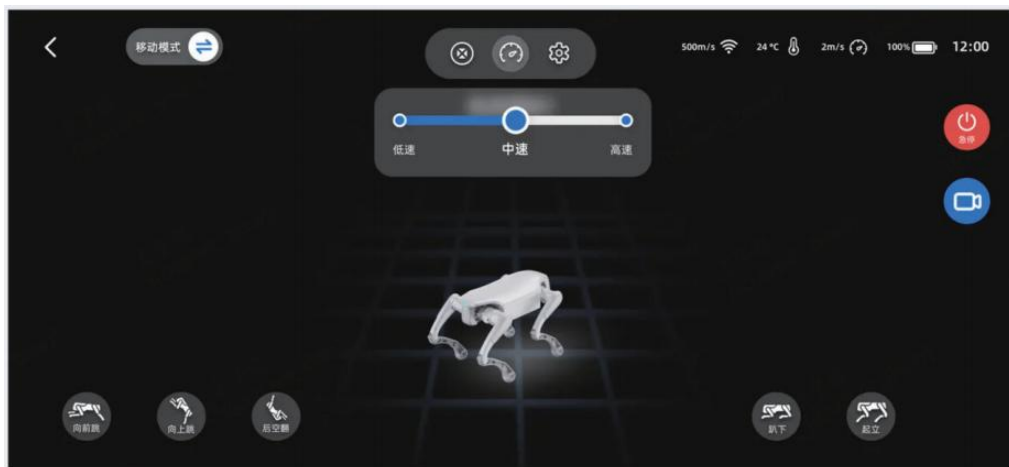

6. 机器人速度设置

**⚠ 警告：特技动作可能影响设备寿命**

执行特技动作会对设备的关节模组施加较大负荷，长时间运行可能导致关节加速磨损，严重影响其使用寿命。请谨慎开启，并合理控制使用时长，以确保设备长期稳定。

产品 OTA升级

OTA升级操作流程

前期准备

操作系统

- Windows

获取刷机包

- OTA官网链接<https://www.zhiyuan-robot.com/DOCS/SW/D1/OTA>

python安装

刷机包依赖Python，使用之前需安装python

- 在浏览器输入下方链接即可安装

<https://www.python.org/ftp/python/3.12.0/python-3.12.0rc3-amd64.exe>

安装时，请务必如下图勾选：



2.4.2 Windows操作流程

升级开始前请您确保机器人电量充足。

使用OTA刷写工具进行升级

1. 下载OTA刷写工具包agibotD1_update_pkg_<版本号>.zip并解压缩。

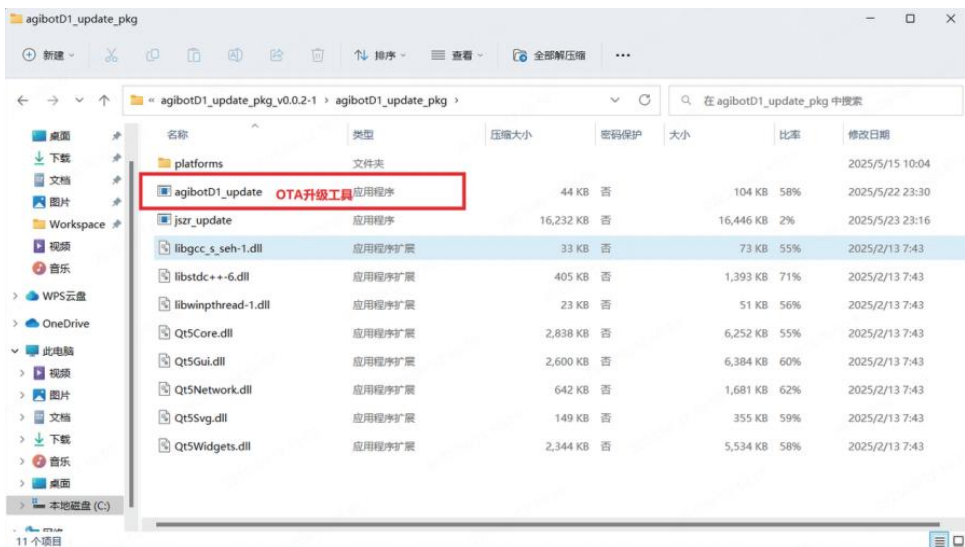

2. 连接机器人WiFi。

3. 在填写好机器人WiFi名称后，点击获取当前版本信息按钮，获取机器人当前版本信息。

4.选择要使用的升级包(文件后缀名为tar.gz)。

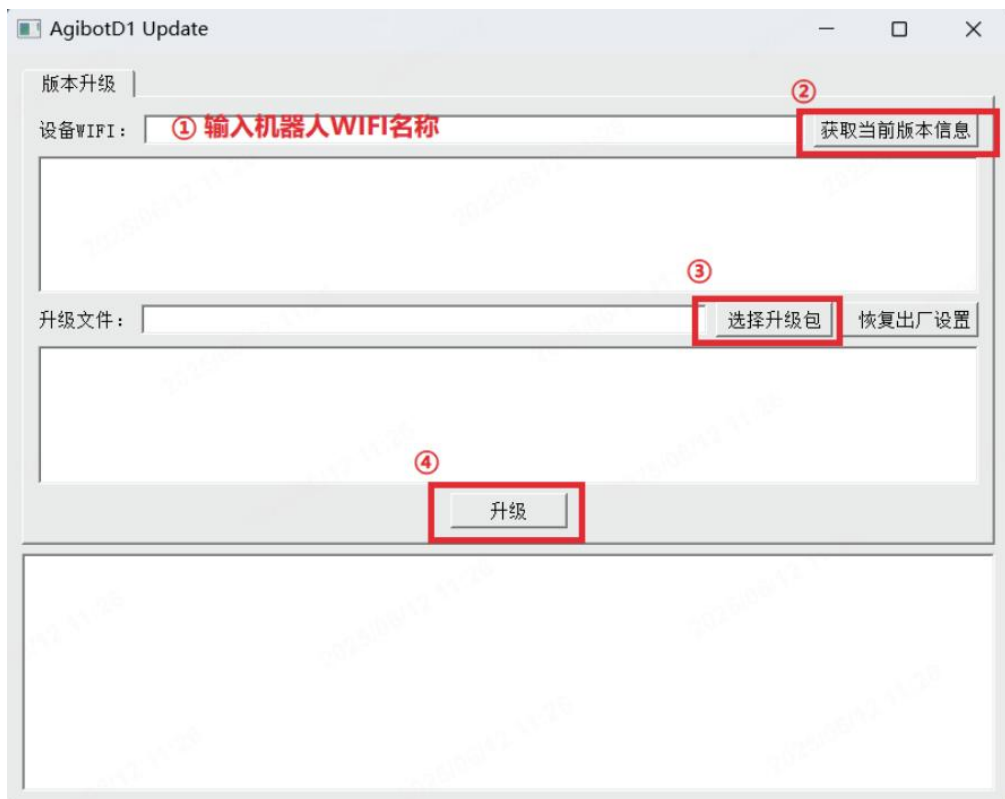

5.确认升级包信息无误后,点击升级按钮进行版本升级,期间会重启机器人



产品参数

分类	规格	说明
基础信息	材质信息	铝合金+高强度工程塑料
	站立尺寸 (长 × 宽 × 高)	635mm×360mm×420mm
	趴地尺寸 (长 × 宽 × 高)	675mm×435mm×145mm
	整机重量 (含电池)	15.5kg
	工作温度	0°C ~40°C
性能参数	最大速度	3.5m/s
	额定负载	5kg
	连续攀爬楼梯高度	16cm
	最大爬坡角度	标准环境30°, 极限可达40°
	跳跃起来离地高度	35cm
电气参数	电池	额定容量4.6Ah, 电压43.2v
	充电时长	1h
	续航时间	1-2h
	续航里程	6km
	充电座输入	AC100-240V 5A
	充电座输出	50.4V 252W

注释说明:

- (1)充电时长数据为在标准环境温度 25°C 下测得
- (2)续航里程数据为在速度1m/s, 无负载工况下测得
- (3)功能拓展接口使用说明, 详见拓展说明手册;
- (4)详细的保修条款, 详见产品保修手册;
- (5)以上参数为实验室测试数据, 实际表现可能因使用环境、操作方式等因素有所差异, 请以实际为准;

故障排除

常见问题	处理措施
遥控无法连接机器人怎么办	先确认机器人已启动,然后确认遥控器后台无其他版本的APP正在运行。若依然无法连接机器人,请重启机器人和APP后再次尝试连接。
连接机器人后手柄操作没有反应怎么办	确认手柄是否已经连接到正确的机器狗WiFi。 若已连接但依然无法操控,请等待10秒后再次尝试操控机器人。若仍无反应,请重启机器人。
机器人自己停止运动是正常现象吗	可能是触发机器狗保护功能,请等待10分钟后再次尝试。 若依然无法控制机器狗继续运动,请先检查电量是否充足,再检查手柄信号是否断

产品运输

箱的尺寸为64cm*46cm*41.5cm，带箱运输前请将电池从机器狗中取出，运输过程中务必保证运输箱正面朝上。

存储环境

电源适配器及整机存储时，请放置在干燥阴凉的环境中，避免阳光直射、火源与强电磁场环境。推荐存放温度为 20°C至 25°C。请勿将产品存放在超过 60°C或低于 -10°C的环境中。长时间存储时，建议温度控制在20°C -25°C、相对湿度为 0 ~ 60% RH，电池总电量控制在 50%以下为佳。

电池注意事项

长时间闲置可能影响电池性能，避免深度放电以保持电池状态。

电池充满后将自动停止充电，但建议断开连接以保持电池状态。

请定期检查电池电量，并每隔约 3个月进行一次充放电以维持电池活性。

如电量低于 20%，应及时充电到 40% -60%进行存放，以避免电池损坏。

轻拿轻放

开机后请避免提起或搬运本产品，搬运前请务必关机处理。

搬运时请轻拿轻放，避免机械冲击导致零部件损坏。

部件名称	有害物质					
	铅 (Pb)	汞 (Hg)	镉 (Cd)	六价铬 (Cr(VI))	多溴联苯 (PBB)	多溴二苯醚 (PBDE)
电路板	×	○	○	○	○	○
金属板	×	○	○	○	○	○
壳体	○	○	○	○	○	○
电池	×	○	○	○	○	○
其他配件	○	○	○	○	○	○

本表格依据 SJ/T 11364 的规定编制。
 ○ 表示该有害物质在该部件所有均质材料中的含量均在 GB/T 26572 规定的限量要求以下。
 × 表示该有害物质至少在该部件的某一均质材料中的含量超出 GB/T 26572 规定的限量要求。



本产品含有可充电锂电池组，报废时对环境有害，请在废弃前按照以下提示将电池从主机中取出，并合理的处置：

- 拆卸电池前请断电以及尽可能用完电量。
- 注意请勿破坏电池外壳以防危险产生。
- 请将取出的电池交由专业的回收机构处理。

售后服务

本产品不支持退货。提供保修服务，参照保修政策。

保修政策

您购买本产品后，保修期自您收到货物当日算起，请您务必保管好保修凭证。满足保修期和保修内容的产品或部件将获得免费售后服务。如果您购买的产品已经超过保修期，您也可以通过另外购买服务的方式来获得我们的帮助。

保修范围

根据具体的情况，我们会为您购买的产品进行相应的维修或者部件的更换。但以下情况将不属于免费保修范围，但您仍可选择有偿售后服务，具体事宜请咨询售后支持：

1. 发生人为的非产品本身质量问题导致的损坏；
2. 发生私自改造、拆装、开壳等行为；
3. 因未按说明书要求正确安装、使用及操作，而造成的损坏；
4. 在超过安全承重情况下使用导致的损坏；
5. 自行加装第三方产品导致的损坏；
6. 机器人内部进水、进杂物或其他化学物质导致的损坏；
7. 由于不可抗力的因素如台风、地震、火灾、雷击、异常电压导致的故障或损坏；
8. 在强磁、强干扰、极高温等恶劣情况下操作导致的故障与损坏；
9. 产品非智元机器人原装正品或无法提供合法的保修凭证时；
10. 自行在非正规渠道维修导致的故障与损坏。

送修说明

- 1.在获取售后服务之前，请务必备份所有数据，并删除重要数据以防数据丢失或泄露，智元机器人不对产品中包含的任何数据的丢失或泄露负责；
- 2.售后服务时默认您授权为售后之目的而进行任何修改、删除数据或恢复出厂设置等操作；
- 3.在送修之前，请先联系智元机器人售后支持，智元机器人将尝试远程诊断和解决您的问题；
- 4.如上述方式无法解决您的问题，您在将产品寄往智元机器人时需先行承担邮寄费用，在收到您需要保修的问题产品后，将对产品进行检测以确定问题和责任；
- 5.若属于产品本身质量缺陷，智元机器人将负责承担检测费、材料费、人工费；
- 6.检测产品不符合免费维修条件，您可选择付费维修，相应的检测费、材料费、人工费及寄回的邮费将由您承担，若不维修可选择原机寄回，相应的邮费将由您承担；
- 7.基于环保与安全的考虑，请勿寄回严重损坏的电池，如已寄回，将对此类电池进行报废处理，不作退还；
- 8.如您提供的收件地址错误导致无法投递或收件人拒绝接受，因此产生的不利后果与损失由您承担；
- 9.为确保您的权益，在签收智元机器人寄送的售后产品时，请您仔细检查产品是否完好，如存在异常，请立即当场拍摄视频或照片并联系智元机器人获取解决方案，如存在未解决的售后问题，也请立即联系智元机器人，否则视为本次售后服务无争议结束。

“
**成为智能机器人
全球领军企业
开创通用机器人生态**
”

To Become a Global Leader
in Intelligent Robots
and Create a General Purpose Robot
Ecosystem



—微信公众号—



—官方网站—

AGIBOT D1 Pro

User Manual



Version Statement

- 01 Legal Statement
- 02 Notes
- 03 Battery and Charging Precautions

Warranty Information

- 01 After-sales Service
- 02 Warranty Policy
- 03 Warranty Exclusion
- 04 Repair Instructions

Product Description

- 01 Product Overview
- 02 Component Introduction
- 03 Tail Light Introduction
- 04 Power Supply Introduction

Product Usage

- 01 Preparation before First Use
- 02 Remote Control User Guide
- 03 APP User Guide
- 04 Product OTA Upgrade

Product Parameters

Troubleshooting

Transportation and storage

- 01 Product Transportation
- 02 Storage Environment
- 03 Battery Precautions
- 04 Handle with Care

Hazardous Substances Information

Legal Statement

Before using this product, users must carefully read the D1 Product User Manual (hereinafter referred to as “this manual”) and strictly follow its instructions when operating the product. The company shall not be liable for any property damage or personal injury resulting from use contrary to this manual. This product consists of multiple components; ensure children cannot access it to prevent accidents. This product is intended for use by individuals aged 18 years or older. To prolong the product's lifespan, avoid using it in high-temperature or high-pressure environments. While this manual strives to provide comprehensive functional descriptions and usage instructions, actual product features may differ from the manual due to ongoing improvements and design changes. In cases where the physical product differs from the manual in color, appearance, or other aspects, the physical product shall prevail.

Notes to be Observed

This manual is applicable to the D1 Pro versions (Product Model ZYCXD105P).

This product should not be used by persons with physical, sensory or intellectual disabilities, or by those without relevant experience and knowledge (including children), unless under the supervision or guidance of a guardian to ensure its safe use.

Do not let children treat the robot as a toy. Please supervise children and pets to keep them away from the main unit when it is working.

If the power cord is damaged, it must be replaced with a special power cord or a special component purchased from its manufacturer or service department.

Do not use in suspended environments without guardrails.

When the robot dog shows abnormal behaviors such as random leg movements or violent shaking during use, please press the *Emergency Stop* button to activate the soft emergency stop function, which will put the moving robot dog into a protective state. The robot dog will automatically lie down. After troubleshooting, it can be operated normally.

Do not place the robot dog upside down. Do not carry it by its legs.

Do not use in an environment above 40°C or below 0°C.

Do not operate the robot in an environment with electromagnetic interference.

Do not operate the robot in an environment with Wi-Fi or 2.4G signal interference.

Before starting the robot dog, please ensure there is more than 1 meter of space around it to avoid collisions with people or objects.

When the robot dog is going up or down stairs or slopes, do not stand on the stairs, platforms or slopes below the robot dog to avoid possible personal injury if the robot dog falls.

Do not place children, pets or any items on the stationary or running main unit.

When handling, do not insert your hands into the range of motion of the joint to prevent pinching or even cutting injuries.

Before cleaning and maintaining the main unit and the charging dock, please turn off the power and unplug the power cord.

Do not wipe the main unit or the charging dock with a damp cloth or rinse them with any liquid.

Do not use any third-party batteries, power cords or charging docks. Only use the standard charging dock provided.

Do not disassemble, repair or modify the main unit, battery or charging dock by yourself. No warranty service will be provided after disassembly, repair or modification.

Do not place the charging dock near a heat source.

Notes to be Observed

Do not discard used batteries at will. They should be handed over to professional recycling agencies for disposal.

If the product is not used for a long time, please fully charge it, turn off the main unit and store it in a cool and dry place. Charge it at least once every three months to avoid over-discharge of the battery.

If you need to transport the product, please ensure that the main unit is turned off and it is recommended to use the original packaging box for packaging.

Please use this product in accordance with the instructions in the manual. Any loss or damage caused by improper use shall be borne by the user.

Notes to be Observed

Joint and wiring harness inspection

Please check if there are any foreign objects affecting the joints, if the wiring harness is damaged, and ensure that the foot pads are intact.

Battery power and camera cleaning

Check the battery level to ensure it is fully charged to prevent sudden drops or falls. At the same time, keep the camera surface on the head and the underside of the body clean to avoid scratching the lens with hard objects. If there is any dirt, wipe it off promptly with a dry soft cloth.

Precautions for Cleaning Products

Do not use liquids containing alcohol or other solvents or corrosive components to clean this product.

Reasonable placement and ground environment

When placing it, please ensure that the legs are in a natural and weight-free state to avoid damage to the leg joints caused by the weight of the machine. Do not let the product lie flat on a hard, sharp or overly bumpy surface to prevent scratches on the bottom lens of the machine.

Foot pads and wear and tear

The foot pads are consumables. Please pay attention to their wear and tear during use. If you notice any wear, damage, or an increase in the noise of the robot's impact with the ground, replace the foot pads promptly to prevent damage to the robot's movement.

Safe use and terrain adaptability

When in use, keep it within your line of sight and maintain a sufficient safety distance. Stay away from obstacles and potential collision hazards. Although the product has good terrain adaptability, it is still necessary to ensure that the terrain meets the requirements.

Speed, turns and complex terrain

Sharp turns are prone to loss of control, especially on steep slopes, uneven or unknown terrain. Avoid risky maneuvers and reduce speed.

Steep slopes and climbing angles

Keep within the rated forward climbing angle and avoid making direct turns at large climbing angles to prevent the robot from losing stability. Please handle operations on steep slopes and terrain with significant inclines properly.

Maximum speed and prohibited usage scenarios

The maximum open speed on a flat terrain can reach 3.5 m/s. Do not use this product on complex, slippery, debris-covered, overly steep slopes or in areas with sharp objects nearby.

Joint and battery status check

If you notice loose joints, inability to stand normally, or excessive noise during operation, please stop using it immediately, turn it off and seek professional maintenance.

Low battery warning

When the battery level is low, the product may not have enough power to perform actions. Please charge it in time to avoid danger

Safety Precautions

Avoid touching the moving parts of the robot with your hands or body to prevent pinching or bumping injuries. At the same time, do not touch the metal parts on the surface of the joint motors to avoid burns.

Product heat dissipation and cleaning

Continuous use for a long time may cause the motor to overheat. Please take regular breaks. If the product is contaminated, please clean it in time.

Power connection specifications

Please connect this product with a fast charging cable that meets the specifications.

Shut-down Precautions

Please shut down the machine immediately after use.

Battery and Charging Precautions

Battery Usage Restrictions

Do not disassemble the battery or use the battery plates in any way by exposing them.

Adapters and Cleaning

Do not use alcohol or other flammable agents to clean the power adapter to avoid potential safety risks.

Dealing with Battery Leakage

If the battery leaks and the electrolyte gets into your eyes, do not rub them. Immediately rinse your eyes with clean water and then seek medical treatment.

Exception handling

If the battery emits an unusual smell, smokes, deforms or shows other abnormal conditions during charging, please immediately unplug the power adapter and check it.

Safe temperature

The power adapter may generate a relatively high temperature during charging. Please avoid touching it for a long time to prevent burns.

Power adapter

Do not use a damaged power adapter. Only use the official power adapter. Non-official power adapters may cause lithium battery leakage, overheating, fire or explosion.

Charging time

The battery charging time should not exceed 24 hours. Overcharging may shorten the battery life.

CAUTION of Battery

Risk of explosion if the battery is replaced by an incorrect type.

Disposal of a battery into fire or a hot oven, or mechanically crushing or cutting of a battery, that can result in an explosion.

Leaving a battery in an extremely high temperature surrounding environment that can result in an explosion or the leakage of flammable liquid or gas.

A battery subjected to extremely low air pressure that may result in an explosion or the leakage of flammable liquid or gas.

FCC Warning

Any Changes expressly or modifications not approved by the party responsible for compliance could void the user's authority to operate the equipment.

This device complies with part 15 of the FCC Rules. Operation is subject to the following two conditions:

- (1) This device may not cause harmful interference, and
- (2) this device must accept any interference received, including interference that may cause undesired operation.

Note: This equipment has been tested and found to comply with the limits for a Class B digital device, pursuant to part 15 of the FCC Rules. These limits are designed to provide reasonable protection against harmful interference in a residential installation. This equipment generates, uses and can radiate radio frequency energy and, if not installed and used in accordance with the instructions, may cause harmful interference to radio communications. However, there is no guarantee that interference will not occur in a particular installation. If this equipment does cause harmful interference to radio or television reception, which can be determined by turning the equipment off and on, the user is encouraged to try to correct the interference by one or more of the following measures:

- Reorient or relocate the receiving antenna.
- Increase the separation between the equipment and receiver.
- Connect the equipment into an outlet on a circuit different from that to which the receiver is connected.
- Consult the dealer or an experienced radio/TV technician for help.

FCC Radiation Exposure Statement

This equipment complies with FCC radiation exposure limits set forth for an uncontrolled environment. This transmitter must not be co-located or operating in conjunction with any other antenna or transmitter. This equipment should be installed and operated with minimum distance 20cm between the radiator & your body.

IC Warning

ISED RSS warning:

This device complies with Innovation, Science and Economic Development Canada Compliance licence-exempt RSS standard (s). Operation is subject to the following two conditions:

- (1) this device may not cause interference, and
- (2) this device must accept any interference, including interference that may cause undesired operation of the device.

Le présent appareil est conforme aux CNR d'Innovation, Sciences et Développement économique

Canada applicables aux appareils radio exempts de licence. L'exploitation est autorisée aux deux conditions suivantes:

- (1) l'appareil ne doit pas produire de brouillage, et
- (2) l'utilisateur de l'appareil doit accepter tout brouillage radioélectrique subi, même si le brouillage est susceptible d'en compromettre le fonctionnement.

ISED Radiation Exposure Statement:

This equipment complies with ISED RF radiation exposure limits set forth for an uncontrolled environment. This transmitter must not be co-located or operating in conjunction with any other antenna or transmitter. This equipment should be installed and operated with minimum distance 20cm between the radiator & your body.

IC exposition aux radiations:

Cet équipement est conforme aux limites d'exposition aux rayonnements RF de l'isedc établies pour un environnement non contrôlé.

Cet émetteur ne doit pas être co-localisés ou fonctionner en conjonction avec une autre antenne ou émetteur. Cet équipement doit être installé et utilisé avec une distance minimale de 20cm entre le radiateur & votre corps.

Other Warnings

- a) any devices capable of operating in the band 5150–5250 MHz shall only be used indoors to reduce the potential for harmful interference to co-channel mobile satellite systems (this requirement does not apply to OEM devices installed in vehicles by vehicle manufacturers);
- b) for devices with detachable antenna(s), the maximum antenna gain permitted for devices in the bands 5250-5350 MHz and 5470-5725 MHz shall be such that the equipment still complies with the e.i.r.p. limit;
- c) for devices with detachable antenna(s), the maximum antenna gain permitted for devices in the band 5725-5850 MHz shall be such that the equipment still complies with the e.i.r.p. limits as appropriate; and
- d) where applicable, antenna type(s), antenna models(s), and worst-case tilt angle(s) necessary to remain compliant with the e.i.r.p. elevation mask requirement set forth in section 7.3.2.4 or 7.3.5.3 shall be clearly indicated.

Product Overview

D1 is a universal intelligent bionic quadruped robot with 12 degrees of freedom, featuring multiple motion gaits and movements. Meanwhile, the Edu version opens up the motion control algorithm development SDK and communication protocol, allowing users to conduct secondary development as needed.



Component Introduction

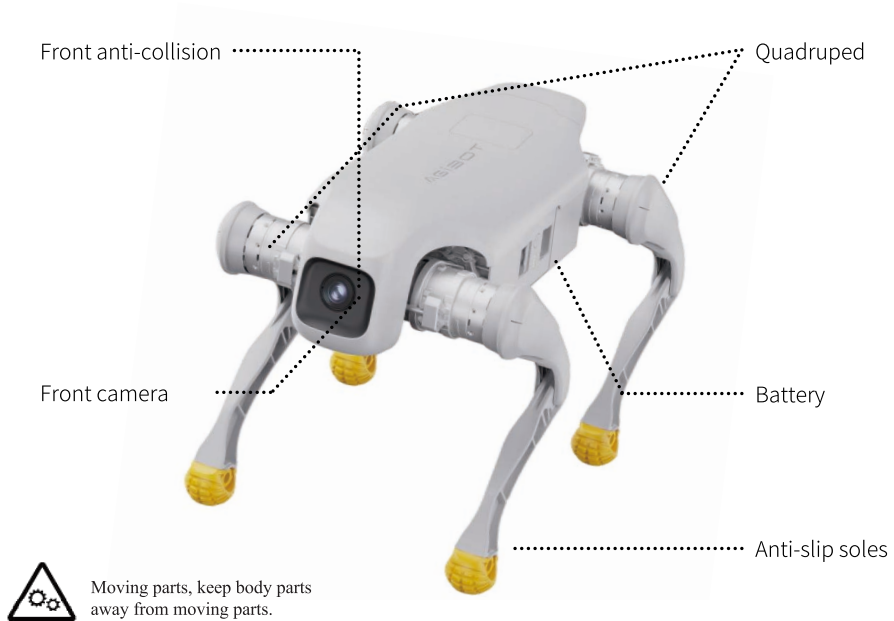

Expansion Interface (Applicable to Edu Version)

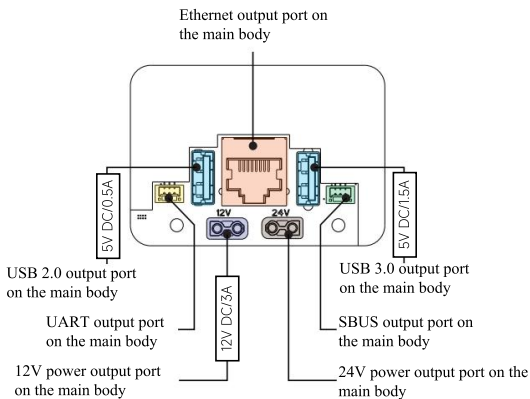

Serial Number	Interface Name	Quantity	Explanation
1	Ethernet port	1	RJ45 connector, supporting 1000Mbps transmission rates, designed for high-speed data transfer. It facilitates network connectivity, remote monitoring, data transmission, and other applications.
2	USB interface	2	Type-A port, used for connecting external storage devices, cameras, sensors, and other USB devices, providing high-speed data transfer and power delivery.
3	Power interface	2	Standard DC power interface provides stable power supply, supporting 12V and 24V voltage outputs, meeting the power requirements of the robot dog and its onboard equipment.
4	SBUS interface	1	Standard SBUS interface for connecting to remote control receivers or other communication devices supporting the SBUS protocol, enabling precise transmission of remote control commands.
5	UART interface	1	Standard UART interface for connecting embedded systems, communication devices, or other UART-protocol-compliant equipment, enabling data exchange and control between devices via asynchronous serial communication.

Disassembly and Installation Method

Use the 2mm hex screwdriver included in the toolkit to loosen the four M4 screws in sequence and remove the cover plate. To reinstall, place the cover back and tighten the screws in order.

Introduction to Tail Lights

Lighting	Light Language	Note
Blue light is constantly on	The system has booted up.	
Blue flashing	Booting up...	
Constantly illuminated in white	Laboratory mode	In this mode, your movement ability is enhanced and special tricks are unlocked.
The green light is always on.	Tracking mode activated.	
The yellow light is always on.	The battery power is less than 20%.	The battery is low and the Beast Mode cannot be activated.
The yellow light is flashing.	The battery power is less than 5%	The battery is low and needs to be charged immediately.
The red light is always on	The joint temperature is too high and needs to be cooled.	
The red light is flashing.	System error. Please contact after-sales service.	

Power Supply Introduction

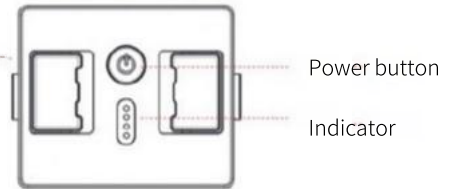

Battery display when the device is powered on

Battery capacity LED indication (idle & discharge)					
NO.	SOC(%)	LED1	LED2	LED3	LED4
1	0 to 14	Flashing	OFF	OFF	OFF
2	15 to 24	ON	OFF	OFF	OFF
3	25 to 49	ON	ON	OFF	OFF
4	50 to 74	ON	ON	ON	OFF
5	75 to 100	ON	ON	ON	ON

Battery display during charging state

Battery capacity LED indication (charging)					
NO.	SOC(%)	LED1	LED2	LED3	LED4
1	0 to 24	Flashing	OFF	OFF	OFF
2	25 to 49	ON	Flashing	OFF	OFF
3	50 to 74	ON	ON	Flashing	OFF
4	75 to 9	ON	ON	ON	Flashing
5	100	ON	ON	ON	ON

Power Adapter

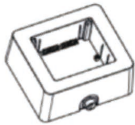

Charging dock ×1



Adapter ×1



Adapter power cord ×1

light up	No powered on
light down	Connect the power supply (100V - 240V)

Charging Instructions

Please ensure that both operators and non-operators present have carefully read this manual and are familiar with the basic operating procedures and safety precautions.



2. Connect the charging dock

Insert the charging cable plug into the bottom port of the charging dock.



2. Connect the power supply

After confirming the connection is secure, insert the power plug into the socket.



3. Place the battery

Insert the battery into the charging dock; Charging begins



To ensure electrical safety:

1. Please follow the steps in the above order and avoid connecting the power supply before the charging dock.
2. Do not plug or unplug the charging dock port while it is powered.

Preparation Before First Use

Unboxing

The robotic dog must be lifted out of the shipping crate as a single unit while powered off. During handling, support the body with both hands to avoid placing weight on the legs. Legs may only be adjusted slightly along their natural joint axes for minor alignment. Never force joints beyond their limits by bending against their natural range of motion.

Improper handling may cause joint damage, encoder misalignment, or abnormal standing!

Power On

Remove the robot dog from its packaging box and place it on a flat surface. Take out the battery and insert it into the robot dog's battery compartment. Briefly press the power button once, then hold it down for at least 3 seconds. The robot dog will power on successfully once the LED light on its head stops flashing.

Power Off

Ensure the robot dog is in a lying-down position. Briefly press the power button once, then hold it down for at least 3 seconds. Once all LEDs on the battery have turned off, the device will enter the shutdown state.



Remote Control User Manual

Product Use Statement: Due to the continuous upgrading of the product's software version, some functions, operation methods, or interface displays may differ from the descriptions in this manual.

The same. If you have any questions or operational confusion, please contact the official customer service at any time for technical support.

Remote Control Introduction

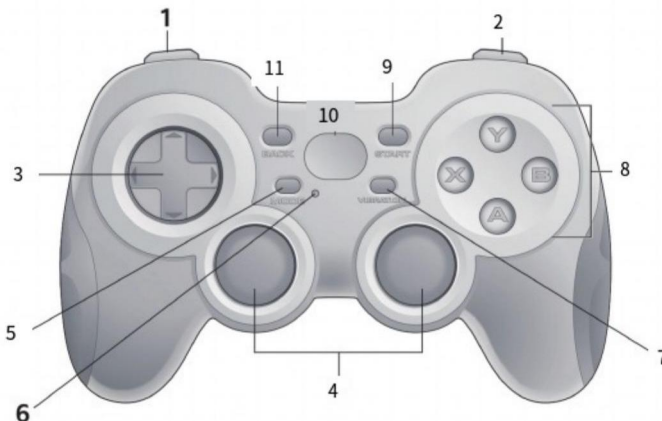

Operation Instructions

Key Position	Names and Functions of the Remote Control Keys for D1 Pro
Left mouse button / trigger	LB and LT buttons
Right-click / Trigger	RB and RT buttons
Direction keys	Left cross key
Joystick	LS: Left Stick (Forward, Backward, Move Left, Move Right) RS: Right Stick (Rotate direction)
Mode button	/
Mode/Status indicator light	Status indicator light
Vibration button	/
Four action buttons	Function keys A, B, X and Y
"START" button	START button
Button	/
Back button	/

Connection method

1. Remove the battery and insert it into the battery compartment of the robot dog. Press briefly.

Press the battery power button once, then hold it down for 5 seconds. Release it and wait for 20 seconds. The startup is now complete. At this point, the battery indicator light shows the current remaining battery power of the robot dog.

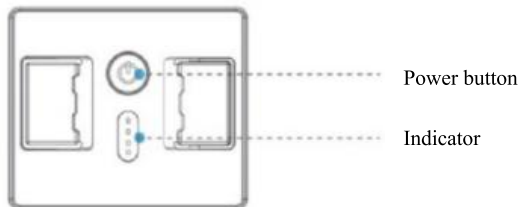

2. Check above the remote control to ensure it is in the X position.

3. Press LB + Y to make the robot dog stand up, and gently push the left joystick forward to try to control it.

If the robot dog does not respond when you move it forward, press the MODE key and then gently push the left joystick forward.

Operation Instructions

Key Position	Action	Button
Switch between regular mode and laboratory mode		START+BACK
General actions	Stand up	LB+Y
	Damping (slowly crouch down)	LB+X
	Drop (Emergency stop)	LB+RB
Movement action	Move left and right, forward and backward	Left Stick
In-place movements	In-place / Mobile switching	START+B
	Pitch adjustment	Push the right joystick forward/backward
	Horizontal turn	Push the right joystick left or right.
	Left/Right probe	X/B
	Tall/short stature	Y/A
Stunt performance	Jump up	RB+A
	Jump forward	RB+X
	Backwards somersault	RB+B
	Say hello	RB+Y
	Stand with both legs	LB+A

Warning: Stunt actions may affect the lifespan of the device.

- Regular mode: Features stable regular movement capabilities and standard actions, suitable for daily use.
- Laboratory Mode: Enhance athletic performance and unlock more stunts.

Stunt actions in Lab Mode put a lot of strain on the joints. Using it for too long can cause faster wear and shorten the device's life. Use with care and keep sessions short to maintain the device's health.

APP User Guide

I. APP Download

Click the link <http://www.zhiyuan-robot.com/DOCS/SW/D1/app> to download the AgibotGO APP.

II. Account Registration and Login

Register and log in to the APP using your mobile phone number or email address.

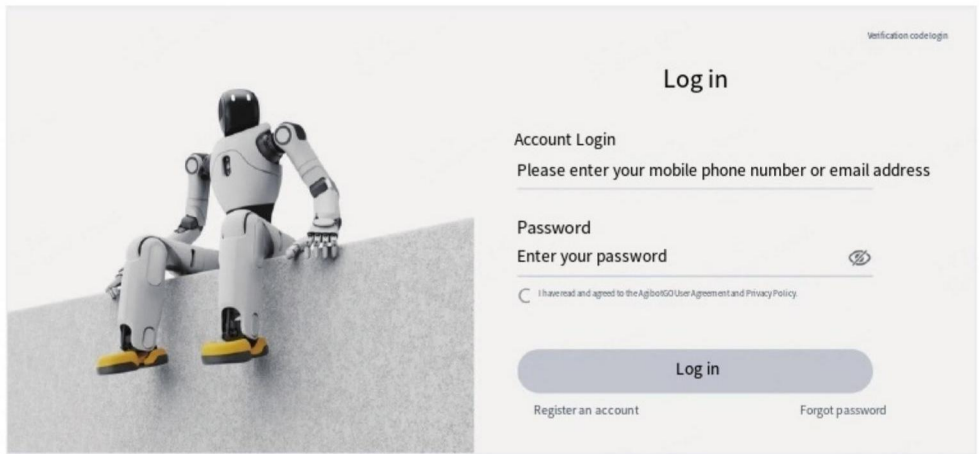

III. Equipment Connection

1. Click the "Add Robot" button

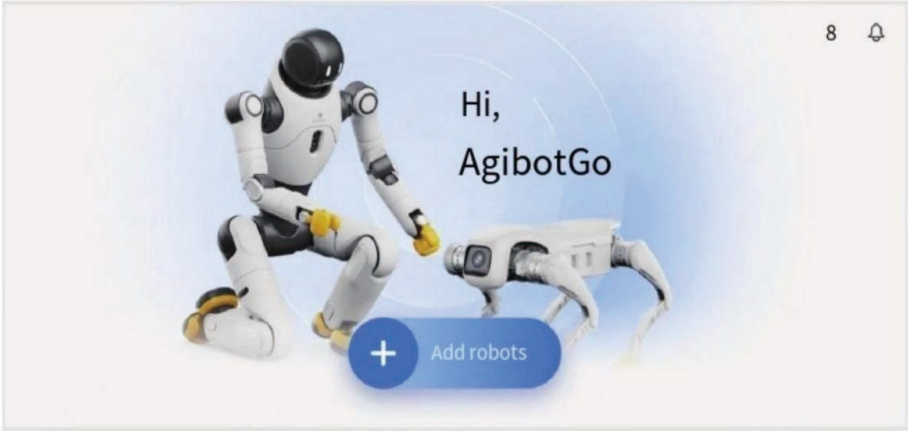

2. Select to add a robot



3. Select the network connection mode. Two modes are supported: WiFi and direct connection to AP.



4. Select WiFi connection mode Automatically read the current WiFi network connected to the mobile phone.

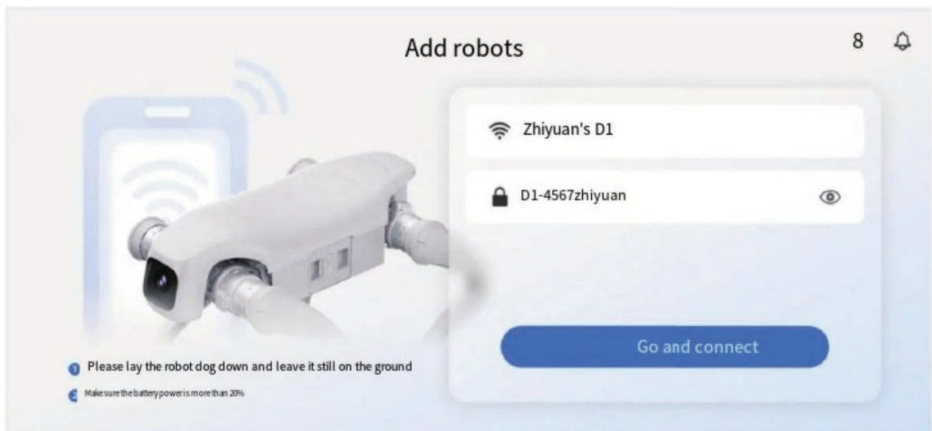

Connecting...

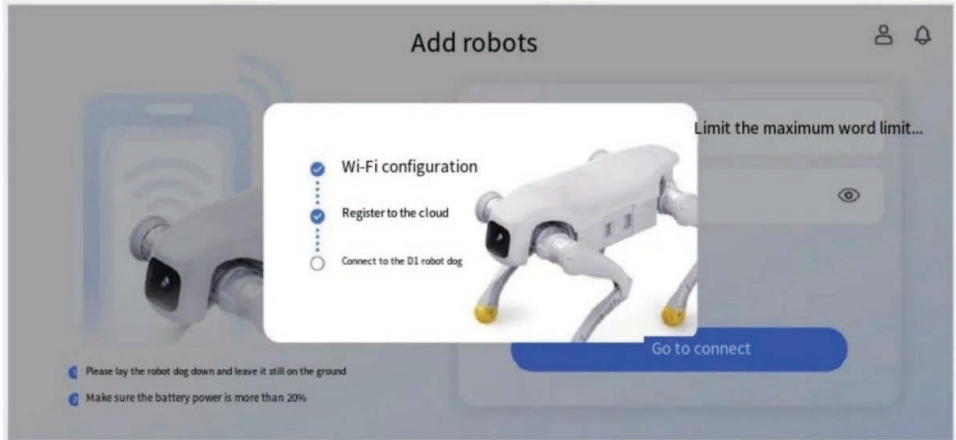

Connection successful. Return to the APP home page.



5. Select AP connection mode

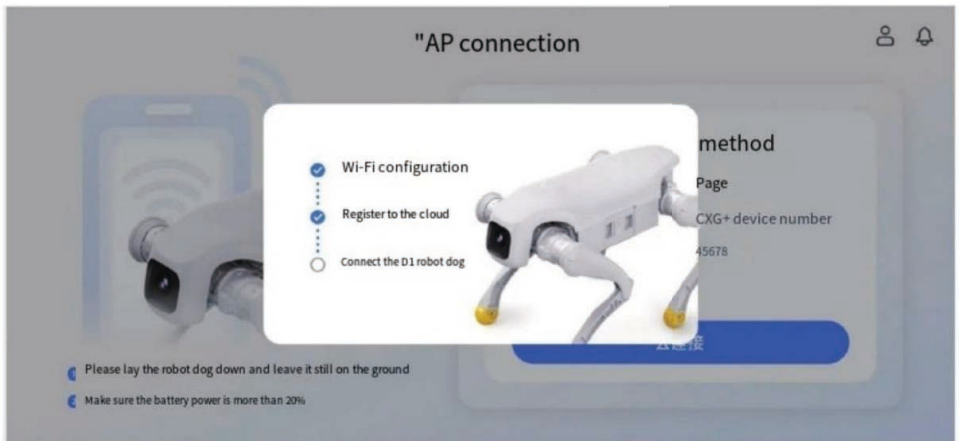
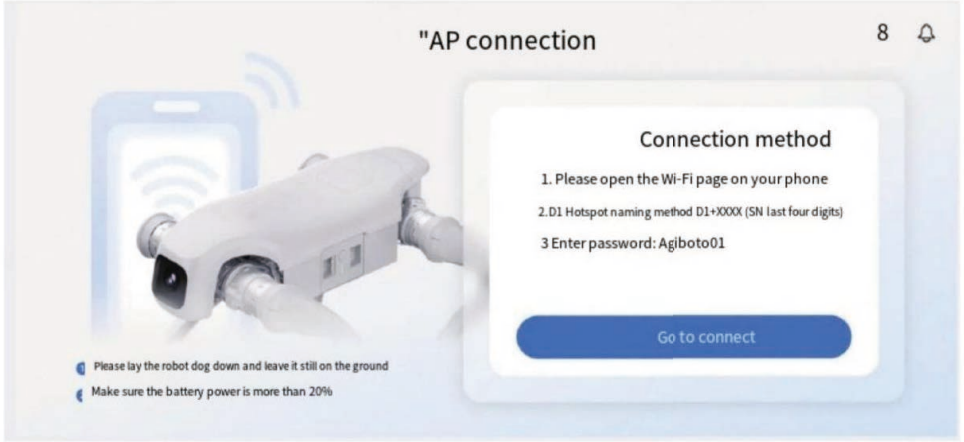

6. After a successful connection, return to the device's home page.



Operation page

1. The upper left corner can be used to switch between mobile mode and stationary mode;



In mobile mode, the left joystick controls the robot's walking direction, and the right joystick controls the robot's rotation direction.

In place mode, the joystick operation is switched to left and right head movement and pitch. The robot cannot walk in place mode.

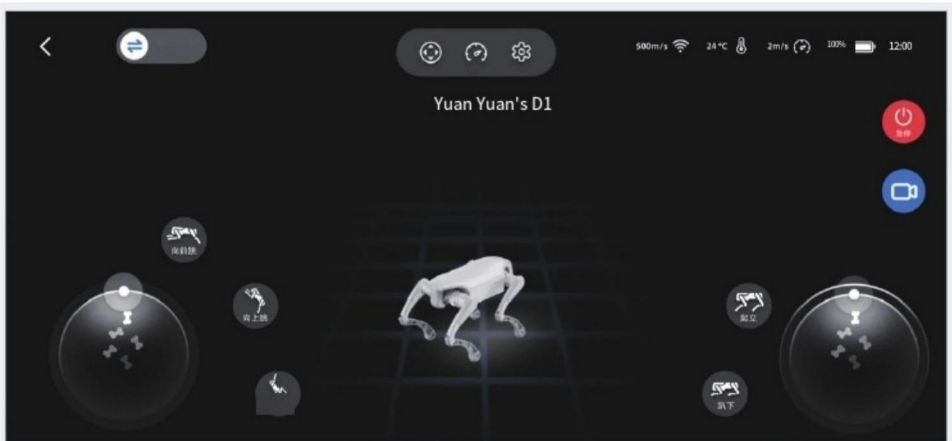

4. Press the red emergency stop button to trigger the emergency stop operation.

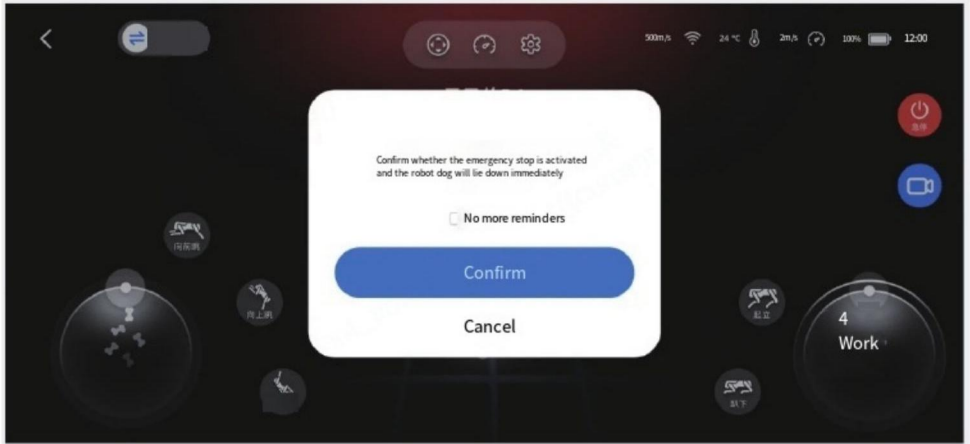

5. Click on the left to perform a forward jump, an upward jump, or a backflip. The prompts indicate these are stunt moves.

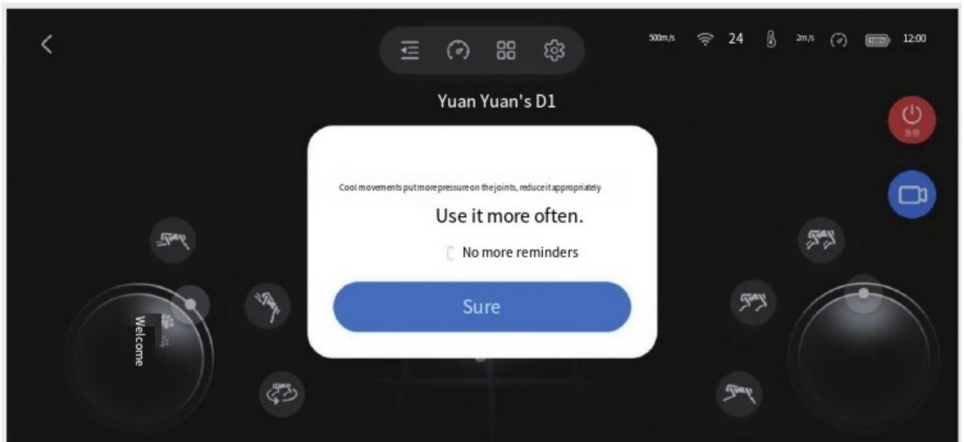

6. Robot speed setting

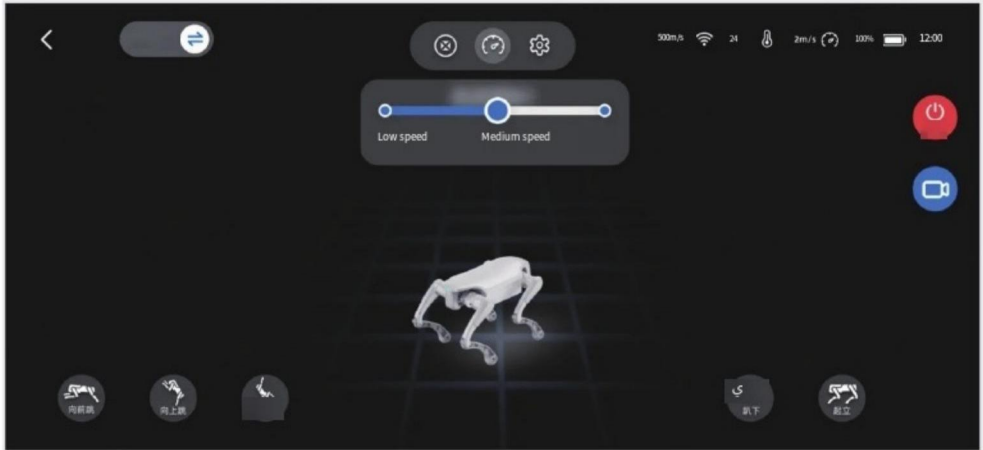

Warning: Stunt actions may affect the lifespan of the device.

Performing stunt actions will impose a significant load on the joint modules of the equipment. Prolonged operation may lead to accelerated wear of the joints, seriously affecting their service life.

Life. Please open it carefully and control the usage time reasonably to ensure the long-term stability of the device.

Product OTA upgrade

OTA Upgrade Procedure
Preliminary Preparation

Operating System

- Windows

Get the flashing package

- OTA official website link: <https://www.zhiyuan-robot.com/DOCS/SW/D1/OTA>

Python in stallation

The firmware update package relies on Python. Before using it, Python needs to be installed. Just enter the link below in your browser to install.

When installing <https://www.python.org/ftp/python/3.12.0/python-3.12.0rc3-amd64.exe>, please make sure to check the boxes as shown in the following figure:



2.4.2 Windows operation process

Please ensure that the robot is fully charged before the upgrade begins.

Upgrade using the OTA flashing tool

Download the OTA flashing tool package agibotD1_update_pkg_<version number>.zip and extract it.

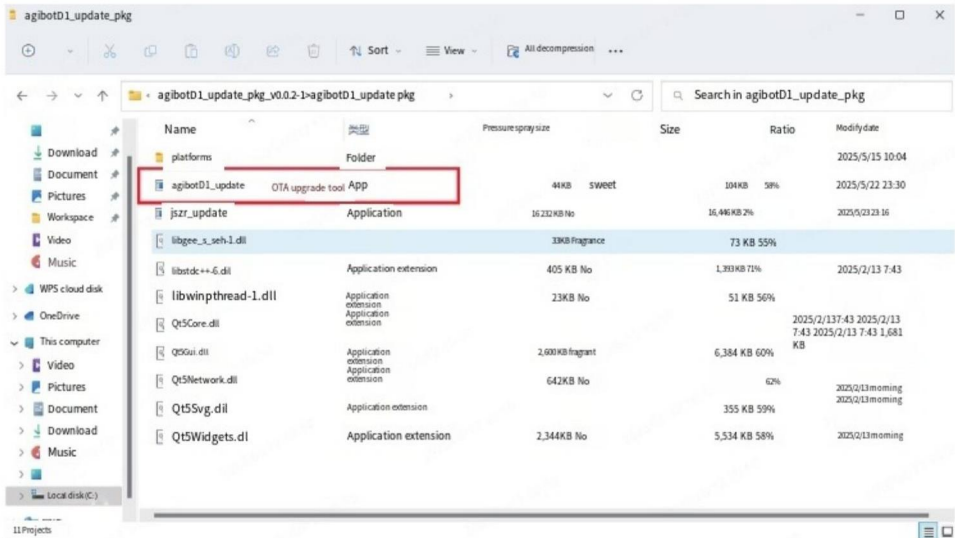

2. Connect to the robot's WIFI.

3. After filling in the robot's Wi-Fi name, click the "Get Current Version Information" button to obtain the current version information of the robot.

4. Select the upgrade package to be used (the file suffix is tar.gz).

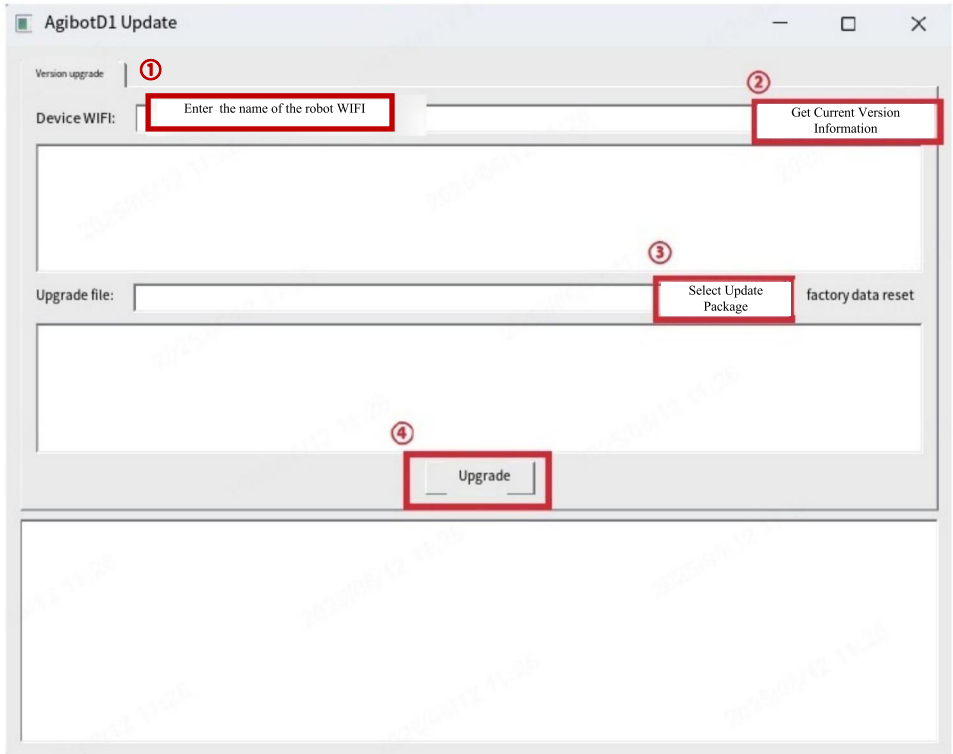

5. After confirming that the upgrade package information is correct, click the upgrade button to upgrade the version. During this process, the robot will restart.

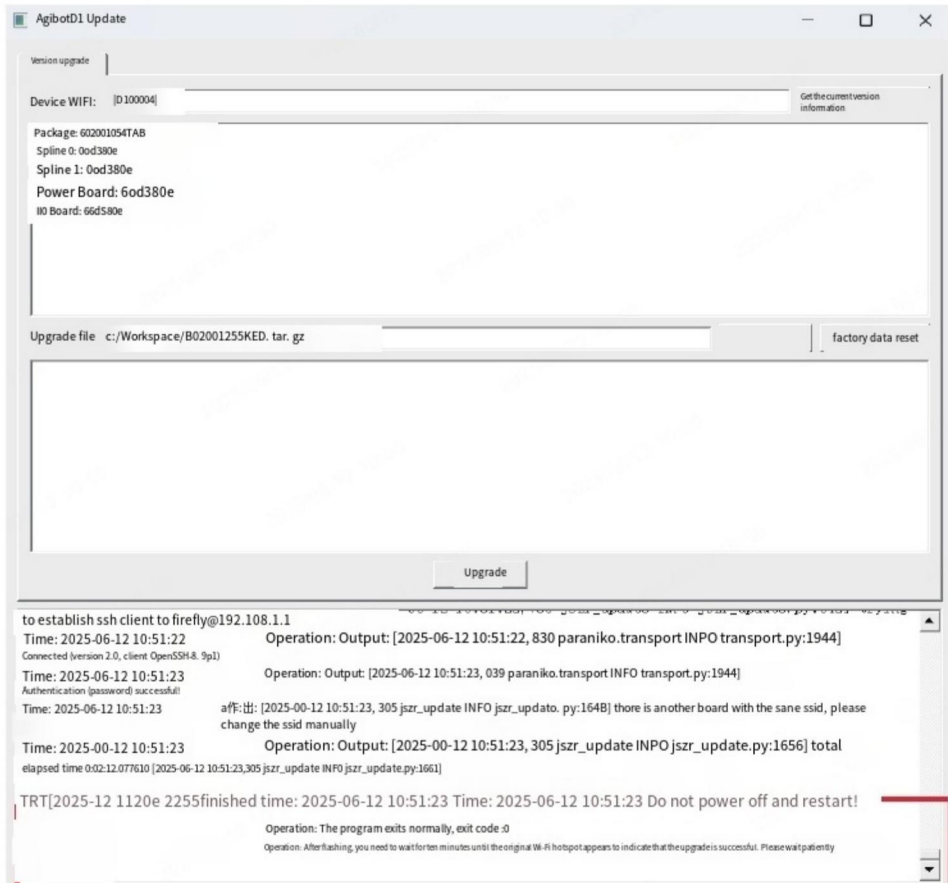

DESCRIPTION OF PRODUCT **Product Parameters**

Category	Specification	Description
Basic Information	Material	Aluminum alloy with high-strength engineering plastic
	Standing Dimensions (L × W × H)	635 mm × 360 mm × 420 mm
	Lying Down Dimensions (L × W × H)	675 mm × 435 mm × 145 mm
	Total Weight (with battery)	15.5kg
	Operating Temperature	0°C ~40°C
Performance Parameters	Maximum Speed	3.5 m/s
	Effective Payload	5kg
	Continuous Stair-Climbing Height	16 cm
	Maximum Climbing Angle	30° standard, up to 40° maximum
	Vertical Jump Height	35 cm
Electrical Parameters	Battery Module	Rated Capacity: 4.6Ah, Voltage:43.2v
	Charging Duration	1 hour
	Battery Life (Operating Time)	1–2 hours
	Operating Range	6 km
	Charging Dock Input	AC100-240V 5A
	Charging Dock Output	50.4V 252W

Notes:

- (1) Charging time is measured at a standard ambient temperature of 25°C;
- (2) Operating range is measured at 1 m/s speed under no-load conditions;
- (3) For details on the expansion interface usage, refer to the Expansion Interface Manual;
- (4) For warranty terms, please refer to the Product Warranty Manual;
- (5) All parameters are based on laboratory test data. Actual performance may vary depending on environment and operating conditions.

Troubleshooting

Issues	Recommended Actions
What should I do if the remote control cannot connect to the robotic dog?	<ol style="list-style-type: none">1. Ensure the robot is powered on.2. Confirm that no other version of the APP is running in the background on the remote controller.3. If the connection still fails, restart both the robot and the APP, then attempt to connect again.
What should I do if the controller is unresponsive after connecting to the robotic dog?	<ol style="list-style-type: none">1. Confirm that the controller is connected to the correct Wi-Fi network of the robotic dog.2. If it remains unresponsive, wait for 10 seconds and try operating the robot again.3. If there is still no response, restart the robot.
Is it normal for the robotic dog to stop moving on its own?	This may be due to the activation of the robot's protection function. <ol style="list-style-type: none">1. Please wait for 10 minutes and then try again.2. If you still cannot control the robot to resume movement, first check if the battery level is sufficient, and then check if the controller signal has been disconnected.

Product Transportation

The dimensions of the box are 64cm * 46cm * 41.5cm. Please remove the battery from the robot dog before transporting it with the box. During transportation, make sure the front of the box is facing upwards.

Storage Environment

When storing the power adapter and the entire machine, place them in a dry and cool environment, away from direct sunlight, fire sources and strong electromagnetic fields. The temperature should be maintained between 20°C and 25°C . Do not store the product in an environment where the temperature exceeds 60°C or drops below -10°C . For long-term storage, it is recommended to keep the temperature at 20°C - 25°C, the relative humidity at 0 - 60% RH, and the battery charge below 50%.

Battery Precautions

Prolonged inactivity may affect battery performance. Avoid deep discharges to maintain battery health.

While the battery will automatically stop charging once fully charged, it is recommended to disconnect it to preserve battery condition.

Regularly check the battery charge level and perform a charge-discharge cycle approximately every three months to maintain battery activity. If the charge level falls below 20%, recharge it to 40%-60% before storage to prevent battery damage.

Handle with care.

After turning on the machine, please avoid lifting or moving this product. Before moving it, make sure to turn it off. When moving, handle it gently to avoid mechanical shock that may cause damage to the components.

Component Name	Hazardous Substances					
	Lead (Pb)	Mercury (Hg)	Cadmium (Cd)	Hexavalent Chromium (Cr(VI))	Polybrominated Biphenyls (PBB)	Polybrominated Diphenyl Ethers (PBDE)
Circuit Board	×	○	○	○	○	○
Metal Plate	×	○	○	○	○	○
Housing	○	○	○	○	○	○
Battery	×	○	○	○	○	○
Other Components	○	○	○	○	○	○
<p>This inspection is based on the provisions of SJ/T 11364.</p> <p>○ Indicates that the content of the hazardous substance in all homogeneous materials of the component is below the limit requirement specified in GB/T 26572.</p> <p>× Indicates that the content of the hazardous substance in at least one homogeneous material of the component exceeds the limit requirement specified in GB/T 26572.</p>						

This product contains a rechargeable lithium battery pack. It is harmful to the environment when discarded. Please remove the battery from the main unit before disposal and handle it properly:

1. Before removing the battery, please power off the device and deplete the battery charge as much as possible.
2. Do not damage the battery casing to prevent potential hazards.
3. The removed battery must be handed over to a professional recycling agency for proper disposal.

Caution

Risk of explosion if the battery is replaced by an incorrect type;

Disposal of a battery into fire or a hot oven, or mechanically crushing or cutting of a battery, that can result in an explosion;

Leaving a battery in an extremely high temperature surrounding environment that can result in an explosion or the leakage of flammable liquid or gas

A battery subjected to extremely low air pressure that may result in an explosion or the leakage of flammable liquid or gas.

After-sales service

This product is not eligible for return. Warranty service is provided, please refer to the warranty policy.

Warranty Policy

After you purchase this product, the warranty period starts from the day you receive the goods. Please keep your warranty certificate safe. If the product meets the warranty period and the warranty conditions,

Products or components will be entitled to free after-sales service. If the product you purchased is beyond the warranty period, you can also obtain our assistance by purchasing the service separately.

Warranty Exclusions

We will provide corresponding repairs or component replacements for your purchased product based on the specific circumstances. However, the following situations are not covered under free warranty, but you may still opt for paid after-sales service. Please consult after-sales support for specific details:

1. Damage caused by human error not related to product quality.
2. Unauthorized modifications, disassembly, or opening of the casing.
3. Damage resulting from incorrect installation, use, or operation not in accordance with the user manual.
4. Damage caused by usage exceeding the specified safe load capacity.
5. Damage resulting from the installation of third-party products.
6. Damage caused by internal exposure to water, debris, or other chemical substances.
7. Malfunctions or damage caused by force majeure events such as typhoons, earthquakes, fires, lightning strikes, or abnormal voltage.
8. Malfunctions or damage resulting from operation under harsh conditions, including strong magnetic fields, severe interference, or extreme temperatures.
9. The product is not a genuine AGIBOT product or valid proof of purchase cannot be provided.
10. Malfunctions or damage caused by unauthorized repairs through non-official channels.

Repair Instruction

Before seeking after-sales service, be sure to back up all data and delete sensitive information to prevent data loss or leakage. AGIBOT is not responsible for the loss or leakage of any data contained within the product.

1. Requesting after-sales service constitutes your authorization for us to perform any necessary modifications, data deletion, or factory resets for the purpose of servicing the product.
2. Before sending the product for repair, please contact AGIBOT after-sales support. We will attempt to diagnose and resolve your issue remotely.
3. If the above methods cannot resolve your issue, you will be responsible for the initial shipping costs when sending the product to AGIBOT. Upon receipt, the product will be inspected to determine the issue and liability.
4. If the issue is determined to be a manufacturing defect, AGIBOT will cover the costs of inspection, parts, and labor.
5. If the product does not qualify for free repair, you may choose paid repair. The corresponding costs for inspection, parts, labor, and return shipping will be your responsibility. If you decline repair, the product will be returned to you at your expense.
6. For environmental and safety reasons, please do not return severely damaged batteries. If such batteries are received, they will be safely disposed of and not returned.
7. You are responsible for any adverse consequences or losses resulting from an incorrect shipping address you provide or refusal of delivery by the recipient.
8. To protect your rights, please inspect the product carefully upon receipt after service. If any abnormalities are found, immediately take photos or videos and contact AGIBOT for a solution. If unresolved issues remain, contact us immediately; otherwise, the service request will be considered resolved and closed.

“

Become an intelligent robot Global leading enterprise Creating a universal robot ecosystem

To Become a Global Leader
in Intelligent Robots
and Create a General Purpose
Robot Ecosystem

”



Youtube



official website

智元D1售后服务指南

AGIBOT D1 After-Sales Service Guide

报修方式/Methods for Reporting Repairs

我们提供7x12小时（国家法定节假日除外）服务,并承诺在收到请求后30分钟内首次响应,您可通过以下任一渠道联系我们:

- 服务热线: 400-186-0818
- 微信公众号: 智元AGIBOT → 点击“在线咨询” → 选择“售后咨询”
- 服务邮箱: AfterSalesService@agibot.com

We provide 7x12-hour service (excluding national statutory holidays) and guarantee an initial response within 30 minutes of receiving your request. You may contact us through any of the following channels:

- Service Hotline: 400-186-0818
- WeChat Official Account: Zhiyuan AGIBOT → Click “Online Consultation” → Select “After-Sales Support” Service
- Email: AfterSalesService@agibot.com

企业微信售后

Wechat After-sales Support

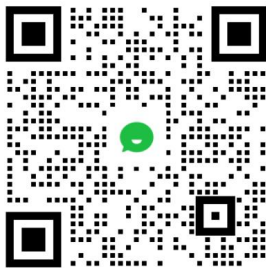

智元创新(上海)科技股份有限公司
咨询热线: 400-186-0818
官网: zhiyuan-robot.com